

Little Folks

- FURNITURE -



Bowood Bunk Bed

Code: BBD009

PLEASE READ CAREFULLY & KEEP FOR FUTURE REFERENCE

Thank you for buying a **Little Folks** piece of furniture

Treated properly it should be a faithful servant for years - and we hope you get the same amount of pleasure from it. Before you do

- please take a few minutes to read these instructions
- we suggest you carefully unpack everything, lay it out on a clean, flat floor and identify everything on the parts list in these instructions. Do not throw away any packaging until you are sure you have all the parts.

If you have any problems assembling the product please call our customer services on 01985 300588 and we will try and help. If for any reason you wish to return the product, you must disassemble the product and pack in the original packaging.

Taking care of your product

Your furniture should require no more than a regular dust off with a soft cloth. If the furniture is not painted then a superior wood polish can be used - but never use polishes containing silicone.

If necessary it can be cleaned with a damp cloth with a mild detergent solution - and then dried with a lint-free cloth. Never clean with abrasives or chemical cleaners.

Direct sunlight or heat from a radiator can stain, discolour warp or crack furniture.

We know furniture can be heavy but try not to drag furniture across the floor as this can damage it.

PRODUCT SAFETY

This product is designed to conform to BSEN747:1 2012+A1:2015

The MAXIMUM thickness of the UPPER BUNK mattress is 23cm.

The recommended size of the mattress is 190cm x 91cm (6'3" x 3'0")

Periodically check that all assembly fixings are tightened properly, care should be taken to ensure that no fittings are loose.

Always follow the manufacture's instructions.

Please ensure that good ventilation is maintained within the room in order to keep humidity low and to prevent mould in and around the bed;

WARNING "High beds and the upper bed of bunk beds are not suitable for children under six years due to the risk injury from falls".

WARNING "Bunk beds and high beds can present a serious risk of injury from strangulation if not used correctly. Never attach or hang items to any part of the bunk bed that are not designed to be used with the bed, for example, but not limited to ropes, strings, cords, hooks, belts and bags"

WARNING "Children can become trapped between the bed and the wall, a roof pitch, the ceiling, adjoining pieces of furniture (e.g. cupboards) and the like. To avoid risk of serious injury the distance between the top safety barrier and the adjoining structure shall not exceed 75mm or shall be more than 230mm.

WARNING Do not use the bunk bed if any structural part is broken or missing;

WARNING Hole covers Not suitable for children under 36 months due to choking hazard.

If you have any problems please do contact us for help on email customerservices@littlefolksfurniture.co.uk or phone our CUSTOMER SERVICES 01985 300588

Parts

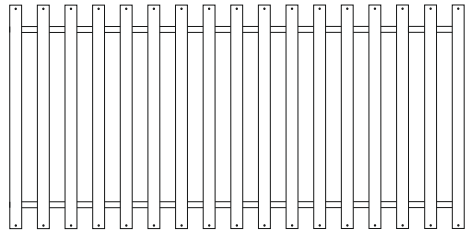
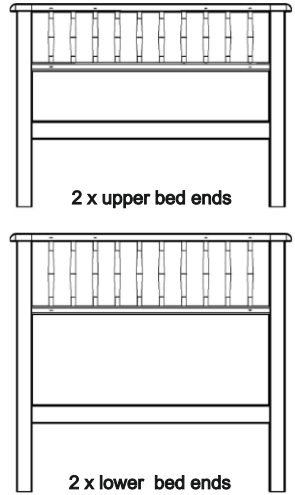
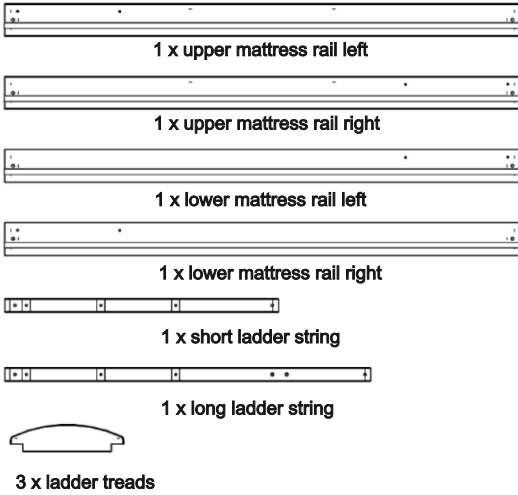

2 x mattress base

Fittings

8 x Large Bolts 9cm 

8 x Barrel Nuts 

16 x Small Dowels 

60 x Screws 3cm 

9 x Large Bolts 6cm 

8 x metal connectors 

8 x 3.5cm bolts 

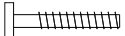
6 x 4cm bolts 

6 x 4.5cm bolts 

Tools Req

Screwdriver 

2 x Allen Keys provided 

small hammer

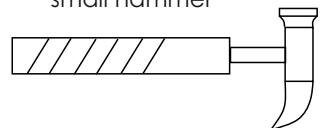

Fitting the mattress rails

16 x wooden dowels

Insert 2 wooden dowels at each end of each rail.

Gently tap the dowels inwards until firmly in place (two outer holes as shown).

There are four different rails so it is worth identifying these parts once the dowels are fitted.

The mattress rails with the holes on the upper edge are used for the upper bed frame. Each lower and upper bed frame will have a left and right hand side rail and this will be explained in more detail during the assembly process.

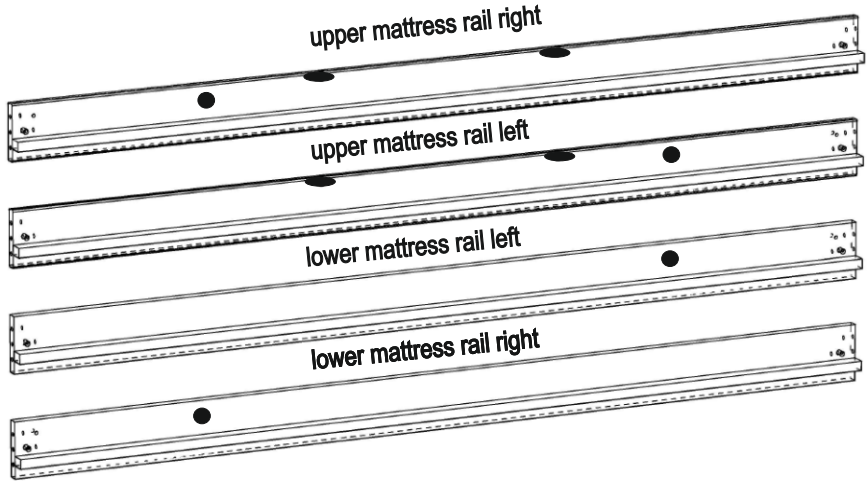

● = indicates drilled holes or metal inserts

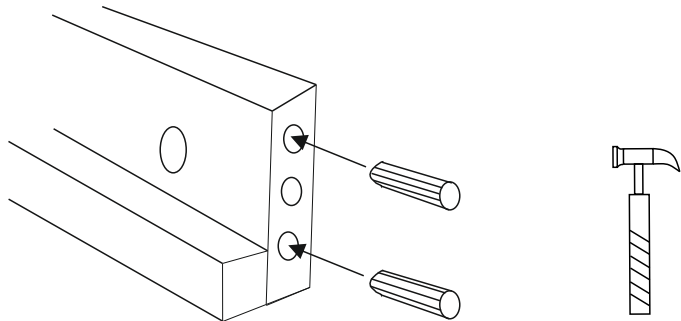

Making the lower bed frame

4 x long Bolts 9cm, 4 x Barrel nuts (two people)

Select both large bed frames (universal bed ends so can go either end of the bed) and one lower left hand mattress rail and one lower right hand mattress rail. Align the lower mattress rails with the dowels locating into the two bed leg holes, inserting the 9cm bolt centrally from the outside of the bed frame, engaging the barrel nut fitted from the inside.

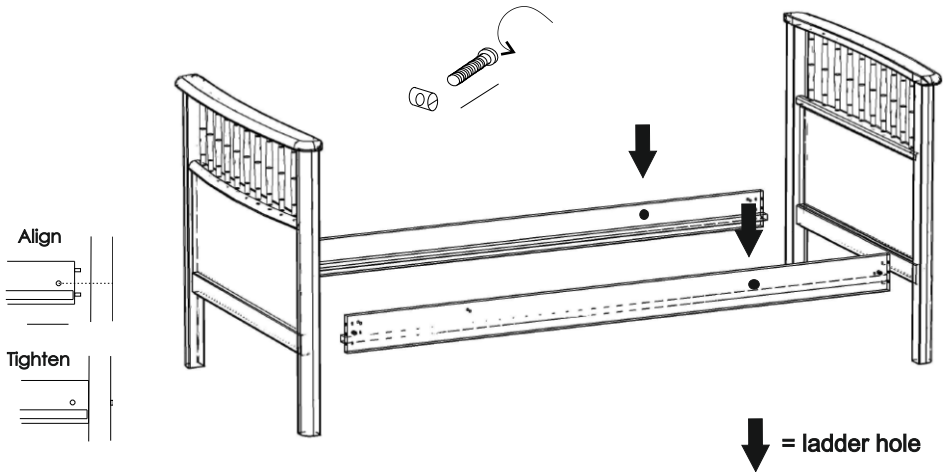

Making the upper bed frame

4 x long Bolts 9cm, 4 x Barrel nuts (two people)

Select both upper bed frames (universal bed ends so can go either end) and one upper left hand mattress rail and one upper right hand mattress rail.

Align the lower mattress rails with the dowels locating them into the two bed leg holes, inserting the 9cm bolt centrally from the outside of the bed frame, engaging the barrel nut fitted from the inside.

Note that the mattress rails MUST have the metal inserts (fitted to the mattress rail edge) facing upwards.

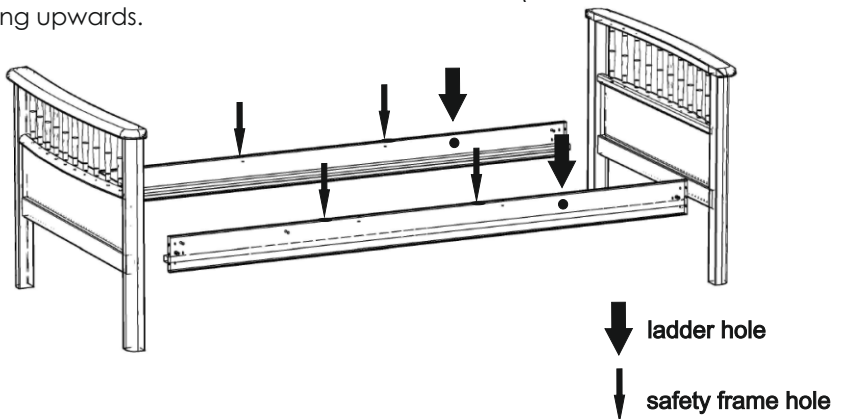

Fit the lower bed mattress base

34 x screws

Carefully roll out the mattress base onto the mattress support pieces fitted on the inside of the mattress rails, webbing on the underside.. Starting at one end of the bed, push the end lath tight up against the bed legs and screw in place using the two end holes in the lath. Now push the other end lath tight up against the bed legs at the opposite end of the bed, screwing down to secure. Once both ends of the base are fitted, position yourself at the centre of the bed, now fix each end of the central lath making sure that the lath is tight against the both mattress rails(some gentle inward pressure will help). Once these three laths are fixed, secure the remaining base laths, screwing down each lath in turn. Repeat the process on the upper bed end

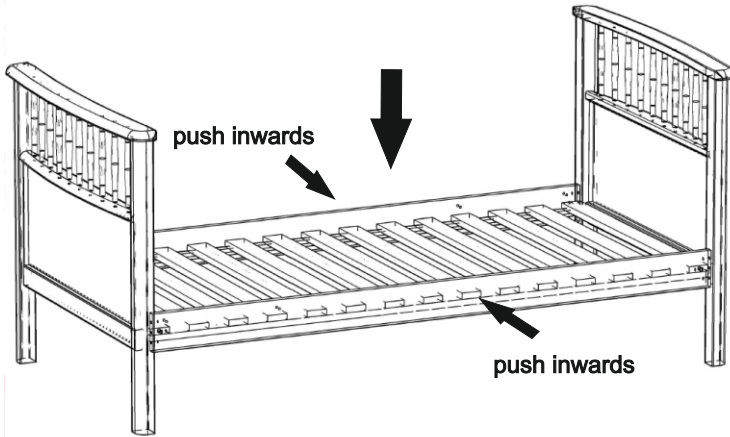

Fit the upper bed base

34 x wood screws

As lower bed base procedure above.

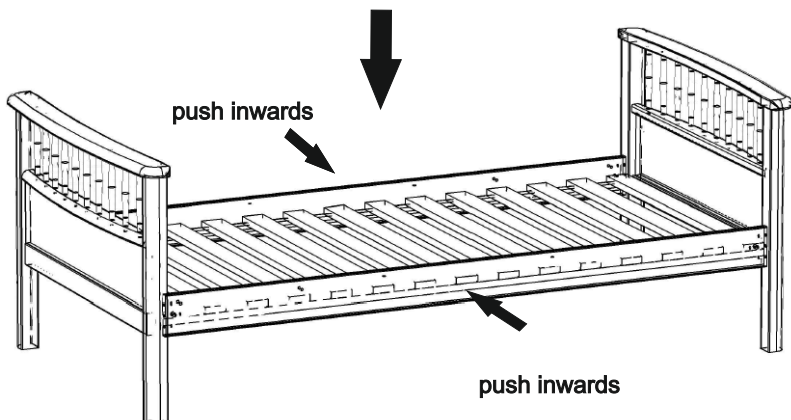

Orientating the bunk bed.

The small side holes on the mattress rails are used to fix the ladder to the bunk bed. You can have the ladder fitted on either the left or right side of the bunk bed (facing the long side of the bed). Simply rotate the bed frames to choose, holes on the left for the LEFT-HAND entrance or holes on the right for the RIGHT-HAND entrance, see images below.

Both upper and lower bed frames need to be aligned the same way, matching the hole sides.

For the purposes of this instruction leaflet we will explain the assembly with the ladder on the LEFT, for RIGHT side fitting, simply mirror the actions explained and illustrated.

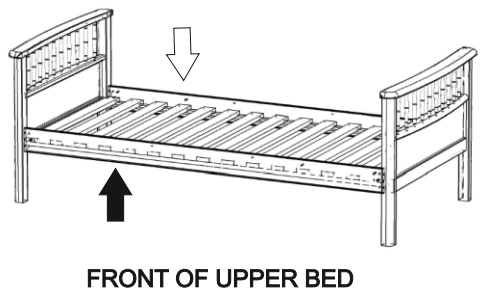
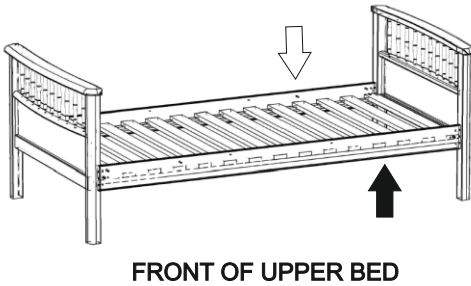
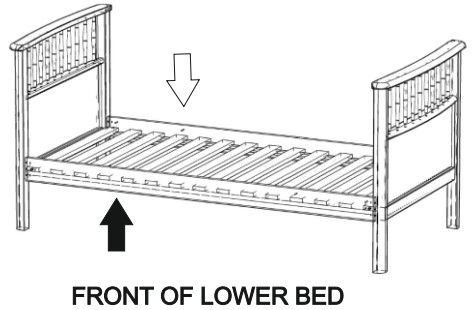
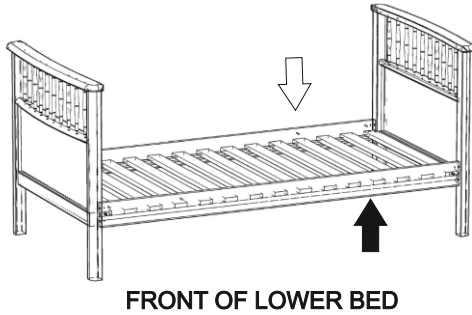

LADDER RIGHT

LADDER LEFT

Match BLACK arrows

Make the bunk

You need: 4 x metal connecting pins and 8 x 3.5cm bolts
(TWO people to lift the upper bed onto the lower bed).

Drop the 4 connecting pins into each of the holes in the lower bed capping, orientating the pin so that it aligns with the intersecting bolt hole on the inside of the bed leg. Once inserted, connect the bolts but do not fully tighten all 8 bolts. Lower the upper bed down onto the 4 connecting pins, checking that each corner leg is in contact with the lower bed capping rail. Insert the remaining 4 bolts and fully tighten. This can sometimes be a little fiddly to connect, gentle movement of each leg and or the fittings normally works. Once all the bolts are connected, tighten the 8 bolts down.

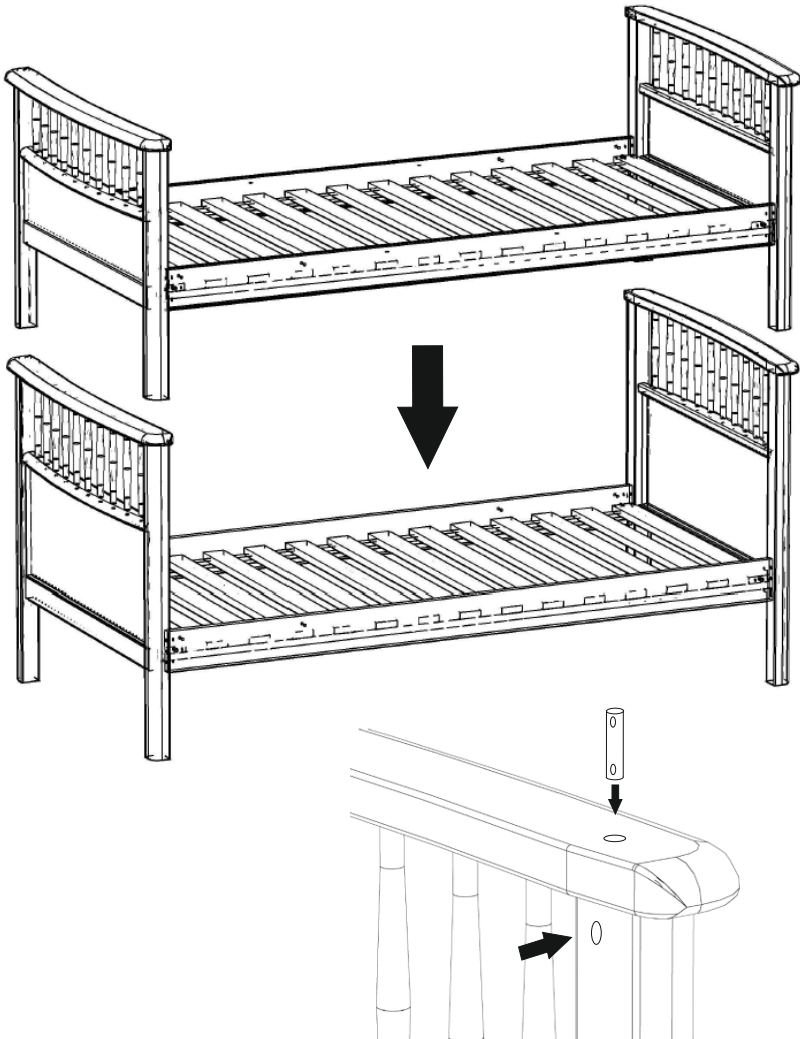

Fix the rear safety frame

6 x long bolts 6cm

Lift the rear frame into position with the holes on the lower long rail downwards. Insert the rear frame (you might need to slightly loosen the rear mattress rail for access) and fit all 6 bolts, 2 at each end and 2 downwards. Once these bolts are ALL connected, tighten them to secure as well as tightening the mattress rail, if loosened.

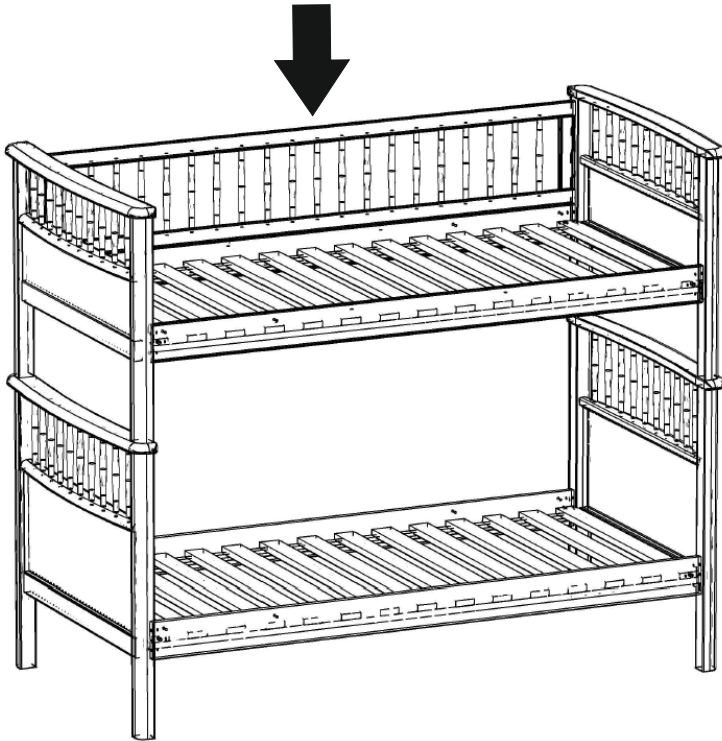

Assemble the ladder frame (ladder LEFT)

You need: 6 x 4.5cm bolts

Orientate the parts as shown, long ladder string on the right and short ladder string on the left. Align each tread into the slots and connect each tread from the rear of the strings using two bolts. Once all the 6 bolts are connected, tighten them to stiffen up the ladder frame.

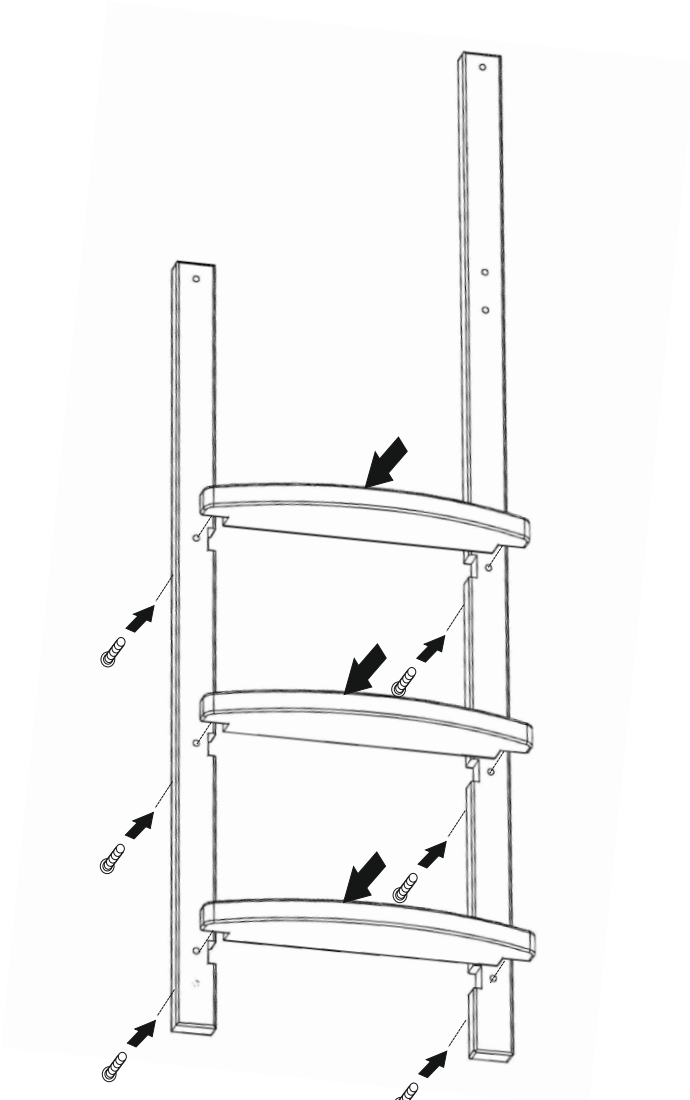

Fit the ladder frame

You need: 4 x 4cm bolts

Orientate the ladder as shown and connect the ladder using the 4 bolts inserted from the inside of the bed. Once all four bolts are connected, rotate to tighten.

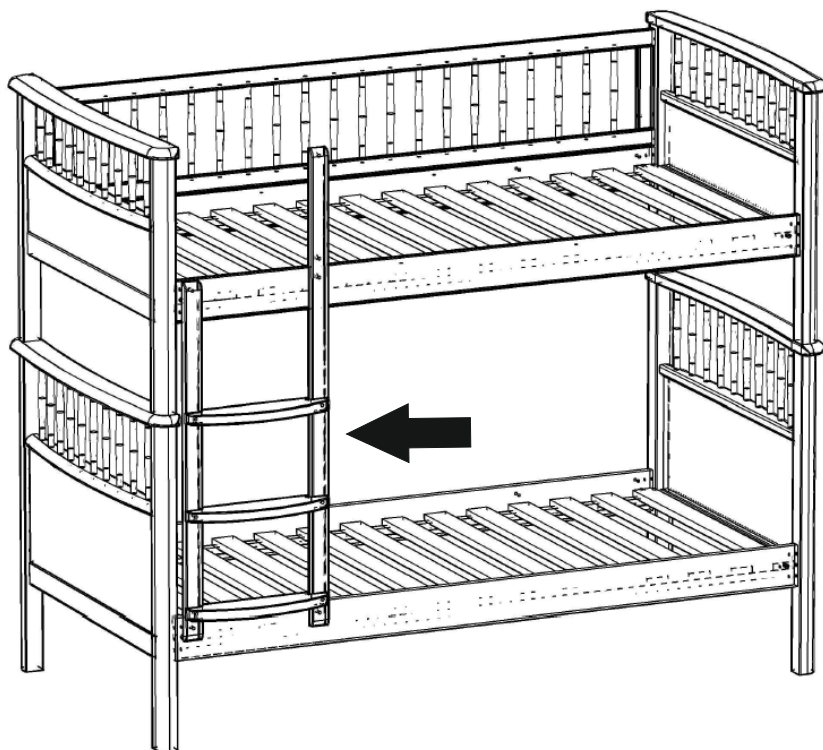

Fit the front safety frame

You need: 2 x 4cm and 3 x 6cm bolts

Orientate the front safety frame as shown and connect the frame using the 3 x 6cm bolts (2 in the right-hand bed leg and 1 downwards into the mattress rail) and 2 x 4cm bolts into the rear of the long ladder string. Once all the bolts are connected, rotate to tighten.

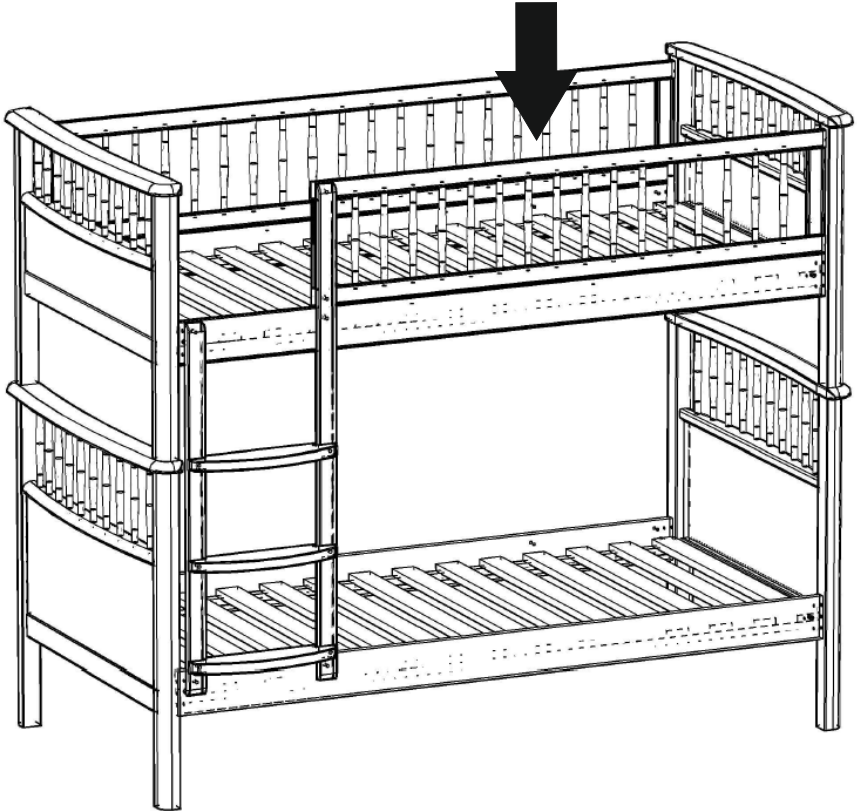

Product safety information

The MAXIMUM thickness of the UPPER BUNK mattress is 23cm.

The recommended size of the mattress is 190cm x 91cm (6'3" x 3'0")

Periodically check that all assembly fixings are tightened properly, care should be taken to ensure that no fittings are loose.

Always follow the manufacture`s instructions.

WARNING "High beds and the upper bed of bunk beds are not suitable for children under six years due to the risk injury from falls".

WARNING "Bunk beds and high beds can present a serious risk of injury from strangulation if not used correctly. Never attach or hang items to any part of the bunk bed that are not designed to be used with the bed, for example, but not limited to ropes, strings, cords, hooks, belts and bags"

WARNING "Children can become trapped between the bed and the wall, a roof pitch, the ceiling, adjoining pieces of furniture (e.g. cupboards) and the like. To avoid risk of serious injury the distance between the top safety barrier and the adjoining structure shall not exceed 75mm or shall be more than 230mm.

Moving the bed

Do Not drag or twist the bed.

Lift the bed into place by supporting both the end bed frames and mattress rails, keeping the bed assembly all together and in unison.

Splitting the bunk bed and removing the mattresses will reduce the weight of the product and help assist with repositioning the product.

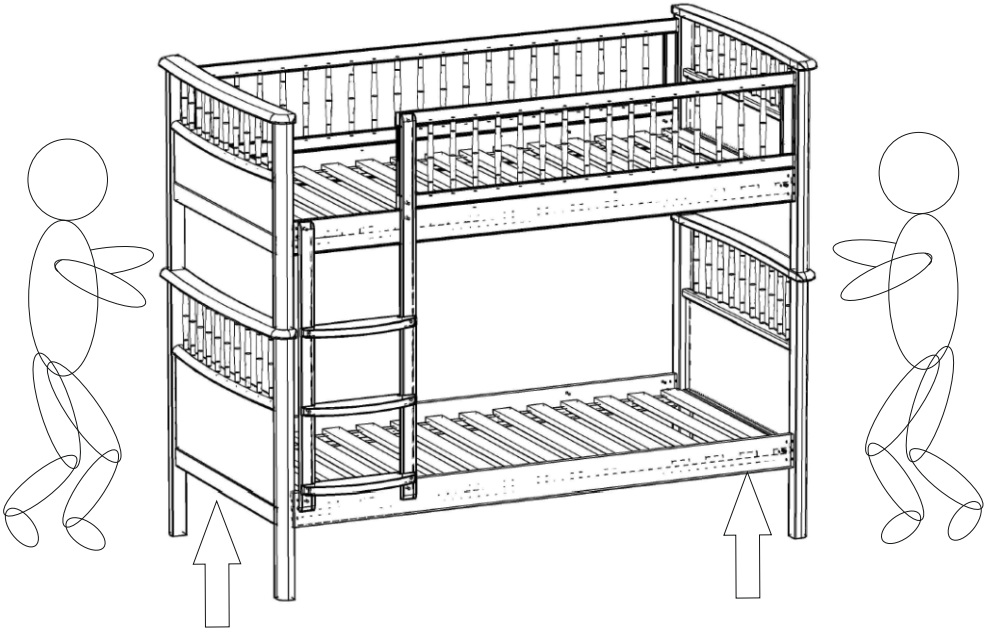

Make two single beds (one lower end and one upper end)

Two people required.

Carefully remove the ladder, remove the front and rear safety frame and mattress bases.

Make two sets of single beds using one lower bed end and one upper bed frame + two mattress rails and one mattress base. Use previous pages within this instruction leaflet for guidance on mattress rail (no restrictions on holes on the mattress rails for single bed assembly)and mattress base connection.

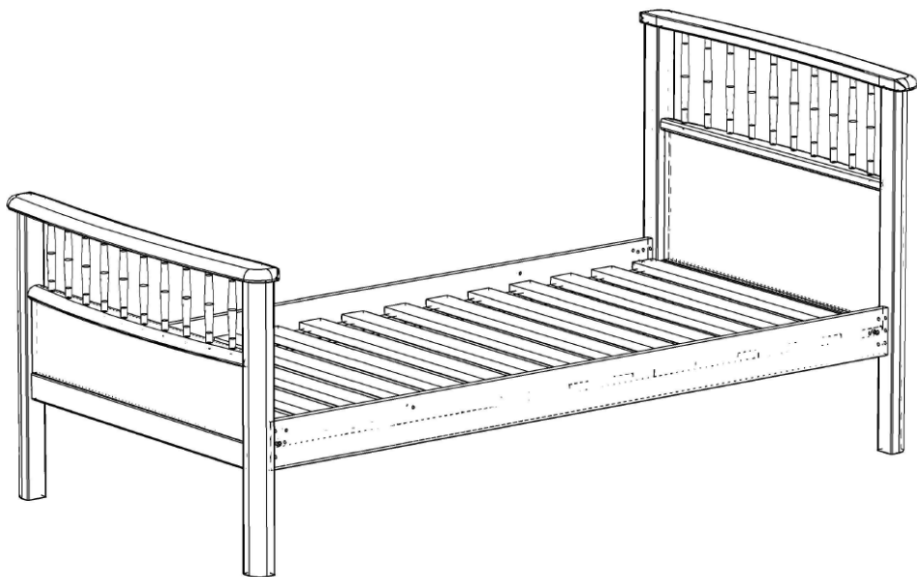

Fit the covers (lower bed only)

4 x wood screws and 4 washers
drop the wooden hole cover into the capping hole. Once inserted, secure using the wood screw from the horizontal hole.

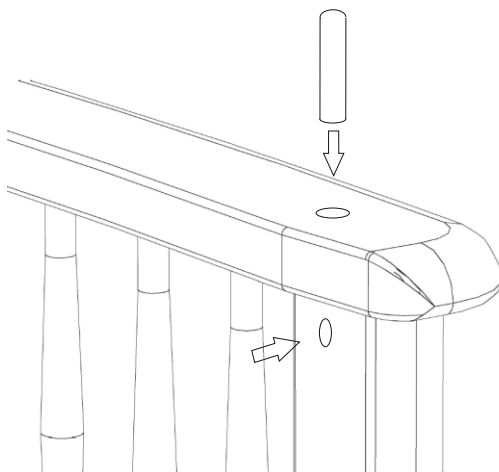

PRODUCT SAFETY

Additional information for single bed use.

Periodically check that all assembly fixings are tightened properly, care should be taken to ensure that no fittings are loose.

Always follow the manufacture`s instructions.

Please ensure that good ventilation is maintained within the room in order to keep humidity low and to prevent mould in and around the bed;

WARNING Do not place this child`s bed near heat sources, windows and other furniture.

WARNING Do not use this child`s bed if any part is broken, torn or missing.

WARNING Hole covers Not suitable for children under 36 months due to choking hazard. The bed can be dismantled for storage or transportation.

Children are likely to play, bounce, jump and climb on beds, therefore the child`s bed should not be placed too close to other furniture or windows, blind cords, curtain pulls or other strings or cords and should be placed either tight to any wall or have a gap of 300mm between the wall and the side of the bed.

Additional or replacement parts should be obtained from Little Folks Furniture.

Moving the bed

Do Not drag or twist the bed.

Lift the bed into place by supporting both the end bed frames and mattress rails, keeping the bed assembly all together and in unison.. Removing the mattress will help reduce the overall weight of the bed.

